

Copilot – How to Assemble Table Base

Install Instructions

Recommended Tools

4mm Hex Allen Wrench

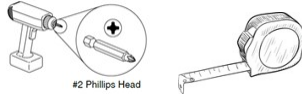

Hardware Included

- Thread M6 x 25mm Screws (Item 4)

Installation

Note:

1. Thread M6 x 25mm Screws (Item 4) Figure A.
2. Fixed or Adjustable Height Base Figure B.
3. Align tapped holes in bottom of column (Item 1) with countersunk holes in base (Item 2) and place column on base. Thread M6 x 25mm screws (Item 4) into column, ensuring screws seat completely into counter-sink. Column should not rotate. Figure C,D.
4. Remove paper from plastic or felt adhesive backed feet depends on flooring or preference (Item 3) and stick to bottom of base as close to edge as possible in locations shown below. Figure C,D.

Figure A

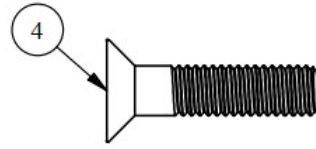

Figure B

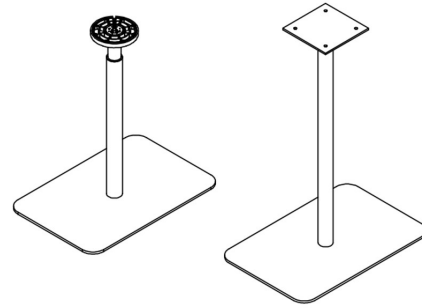

Figure C

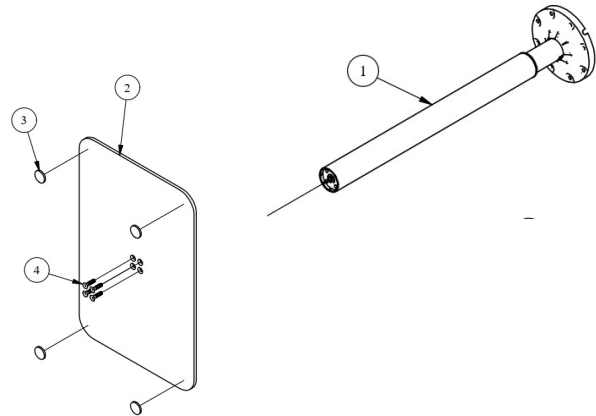
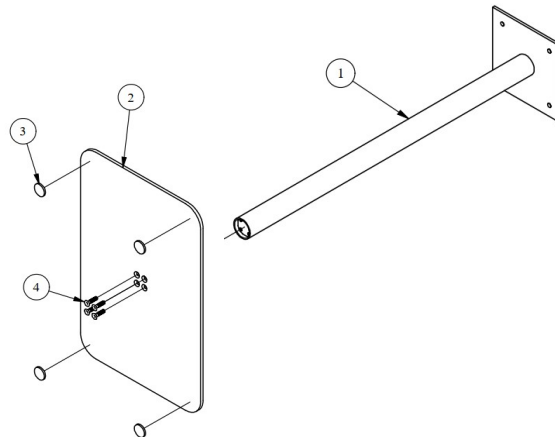

Figure D



Parts List		
Seq	Qty	Description
1	1	Column Assembly or Weldment
2	1	Disk Base
3	4	Adhesive Backed Pad (Plastic)
3	4	Adhesive Backed Pad (Felt)
4	4	M6 x 25mm FHCS Socket Drive

Failure to comply with installation instructions will compromise the safety, durability and performance of this product, which may risk injury to the user of this product and/or diminish the product life cycle. Jasper Group assumes no liability in these instances.