

Somna Metal Foot Installation

Install Instructions

Tools Required

- H4 Hex Driver Bit



- Drill Driver

Hardware Included

- Qty. of 12 - 1/4-20 Flat Head Hex Drive Screws

Installation

Note: Due to the product weight, it is recommended two or more people help with the installation of the sleep sofa replacement foot.

Note: All screws provided must be installed for proper installation and compliance with product warranty.

1. Lay out protective floor covering (cardboard, blanket, etc.)
2. Open box and remove product and foot kit from the carton.
3. Turn unit so the back is on the ground and the bottom of the unit is accessible as shown in Fig. A.
4. Identify the 3 hole pattern cut in the black dust cover located on the bottom of the sleep sofa near each corner as shown in Fig. A.
5. Secure each foot to the sleep sofa frame with quantity of 3 screws per foot as shown in Fig. B.
6. Repeat for each foot.
7. Turn sleep sofa upright as shown in Fig. C.

* OPTIONAL CASTER FEET ASSEMBLY CONFIGURATIONS

- **4 CASTER OPTION:**
Secure the 2 locking caster feet to the front of the sleep sofa & the 2 non-locking caster feet to the rear as shown in Fig. D.
- **2 CASTER/2 STATIC FEET OPTION:**
Secure the 2 static feet to the front of the sleep sofa & the 2 non-locking caster feet to the rear as show in Fig. E.

Figure A

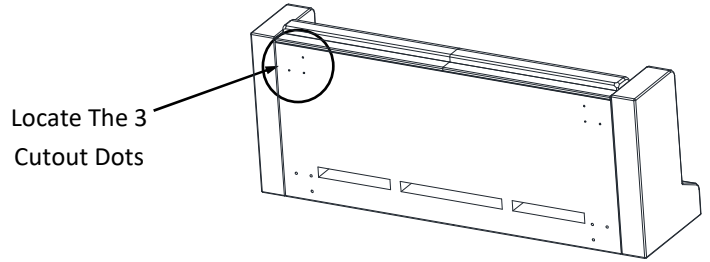

Figure B

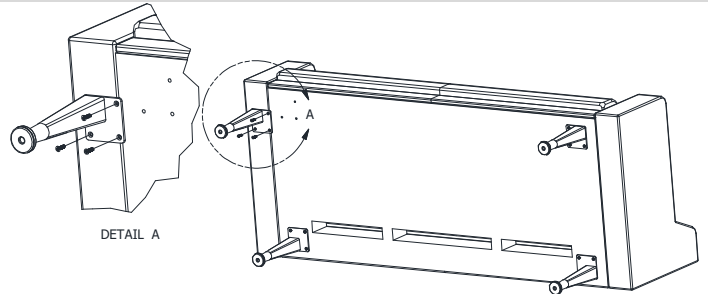

Figure C

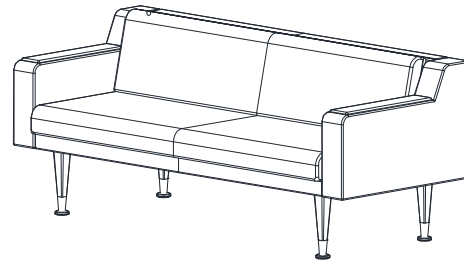

Figure D

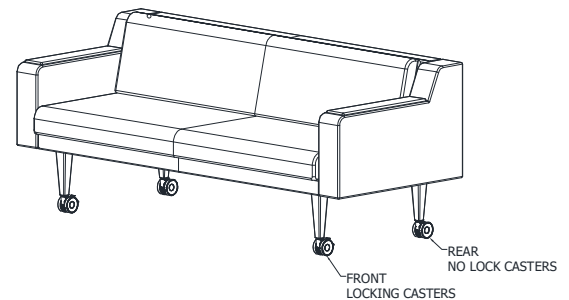

Figure E

