

# Somna Replacement Metal Foot

## Install Instructions

### Tools Required

- H4 Hex Driver Bit



- Drill Driver



### Hardware Included

- Qty. of 3- 1/4-20 Flat Head Hex Drive Screws

### Installation

Note: Due to the product weight, it is recommended two or more people help with the installation of the sleep sofa.

Note: All screws provided must be installed for proper installation and compliance with product warranty.

1. Lay out protective floor covering (cardboard, blanket, etc.)
2. Open box and remove the replacement foot from the carton.
3. Turn unit so the back is on the ground and the bottom of the unit is accessible as shown in Fig. A.
4. Unthread the glide or pull out caster from the bottom of the foot that is being replaced as shown in Fig. B
5. Remove the 3 screws attaching the foot that is being replaced as shown in Fig. C.
6. Secure the replacement foot to the sleep sofa frame with quantity of 3 replacement screws as shown in Fig. D.
7. Thread the glide or insert the caster that was removed from the original foot into the replacement foot as shown in Fig. E.
8. Turn sleep sofa upright.

Figure A

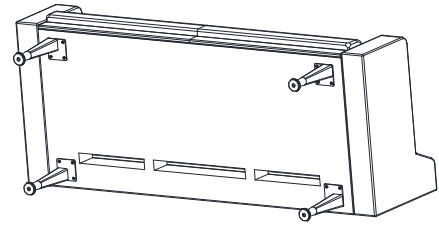

Figure B

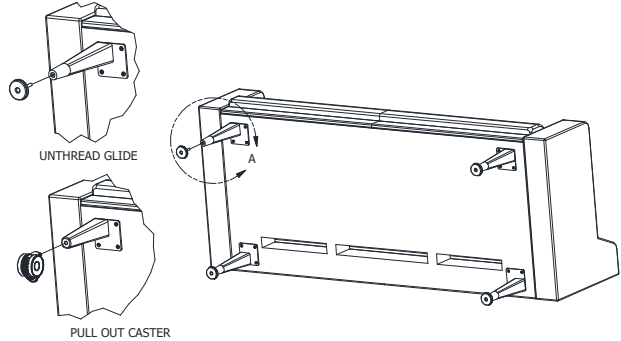

Figure C

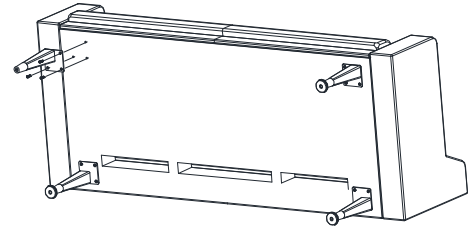

Figure D

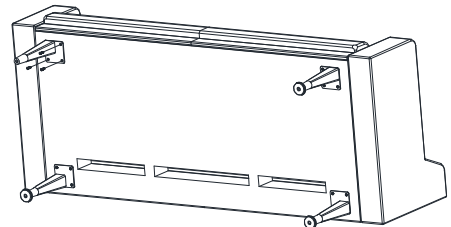

Figure E

